

Pressure Limiting & Isolation Valves PLV, MST-1, MST-2

Ideal for washing machines & dishwashers



MAXISTOP
MAXIMUM POSSIBILITIES

avg.net.au

AVG[®]
Australian Valve Group
A **WATTS** Brand

Point of use Isolation & Pressure Reducing PLV, MST-1, MST-2

The "MAXISTOP" (MST) range is a revolutionary new approach to point of use isolation valves incorporating a pressure limiting function. When it comes to protecting flexible hoses, mixer tap cartridges, fridges and appliances etc., from excess pressure the new MST is the perfect choice.

One of the reasons for the development of the "MAXISTOP" (MST) was to prevent excess pressure build-up within the flexible connectors and tap cartridges within a building. Although it's a requirement to fit a 500kPa boundary reduction valve to the property this will only control the pressure within the hot water service and up to the non return isolation valve to a storage water heater. During the heat up cycle of a storage water heater the water within the cylinder will expand and increase the pressure to what ever the pressure and temperature relief valve (PTR) is set to, in most cases this is 1400kPa. This high pressure will remain within the hot water plumbing system until a tap is opened, this can be up to 23 hours per day. It's important to note that the maximum allowable pressure for tap cartridges is 500kPa, cross flow issues may occur when subjected to excess pressure and this cross over could result in a rise in pressure within the cold water plumbing pipe work also.

DIMENSIONS

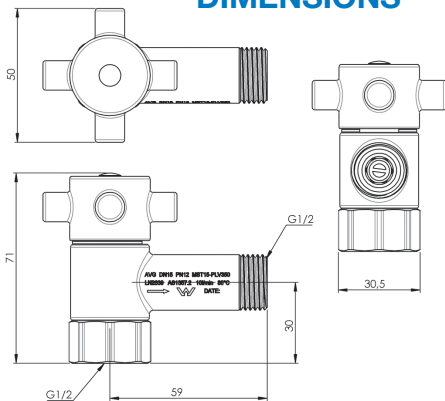

MST-1 & MST-2 SPECIFICATIONS

Body & Handle:	Polished Chrome
Ball:	DZR Brass
Inlet:	15mm female
Outlet:	MST-1 All positional swivel 15mm male
Outlet:	MST-2 All positional swivel 20mm male
O rings:	EPDM
Seals:	PTFE/EPDM
Pressure setting:	350kPa
Flow rate:	10 liters/min
Max temp.:	80°C
Approvals:	AS1357.2 Watermark

MST-1
Suitable for any
15mm point of
use isolation
applications



MST-2
Ideal for washing
machines and
dishwashing
machines to help
reduce water
hammer and most
pipe noises



FEATURES

- High quality polished chrome finish
- No need for thread seal tape/sealant
- Quick and easy installation with a soft seal inlet connection
- Firm all positional swivel outlet connection
- Smooth quarter turn on/off operation
- Optional hot or cold indicator buttons
- Plumbing system, tap cartridges, hose and appliance over pressure protection
- Ideal for washing machines and dishwashing machines to help reduce water hammer and most pipe noises
- Pressure limiting function (factory set 350kPa)